User's Guide

Publication number E2613-92006
June 1999



For Safety information, Warranties, Regulatory information,
and publishing information, see the pages at the back of this book.

© Copyright Hewlett-Packard Company 1997-1999
All Rights Reserved.

HP Wedge Probe Adapter

Before you begin

IMPORTANT — Read this guide before you begin

Before you begin installing and using your HP Wedge Probe Adapter you should have an understanding of how it works. Learn the theory behind the HP Wedge Probe Adapter and the different applications for using it.

In this manual

Chapter 1 - Provides theory behind the HP Wedge Probe Adapter and other background information you need to understand before you use the probe.

Chapter 2 - Provides cleaning, installing, connecting, and repairing information on the HP Wedge Probe Adapter.

Equipment supplied

The HP Wedge Probe Adapter is available in several configurations of pin spacing and signal probing. Each model includes a User's Guide and a magnifying lens, in addition to the following adapters:

HP E2613A	One 0.5 mm x 3-signal HP Wedge Probe Adapter
HP E2613B	Two 0.5 mm x 3-signal HP Wedge Probe Adapters
HP E2614A	One 0.5 mm x 8-signal HP Wedge Probe Adapter
HP E2615A	One 0.65 mm x 3-signal HP Wedge Probe Adapter
HP E2615B	Two 0.65 mm x 3-signal HP Wedge Probe Adapters
HP E2616A	One 0.65 mm x 8-signal HP Wedge Probe Adapter
HP E2643A*	One 0.50 mm x 16-signal HP Wedge Probe Adapter
HP E2644A*	One 0.65 mm x 16-signal HP Wedge Probe Adapter

* 16-signal HP Wedge Probe Adapters include 3 removable jumpers (HP part number 1258-0141 for quantity of 1 jumper)

Color coding

For ease of identification, 0.5 mm HP Wedge Probe Adapters are color-coded orange and 0.65 mm HP Wedge Probe Adapters are color-coded green.

Overview

This guide explains how to install the HP Wedge Probe Adapter on thin quad flat pack (TQFP) or plastic quad flat pack (PQFP) surface-mounted integrated circuits. This probing solution provides accurate, mechanically non-invasive contact to the TQFP/PQFP package legs. Accessories such as flexible leads enable you to connect to various oscilloscope probes and logic analyzers. When these guidelines are followed, the HP Wedge Probe Adapter will provide you with many cycles of problem-free probing.

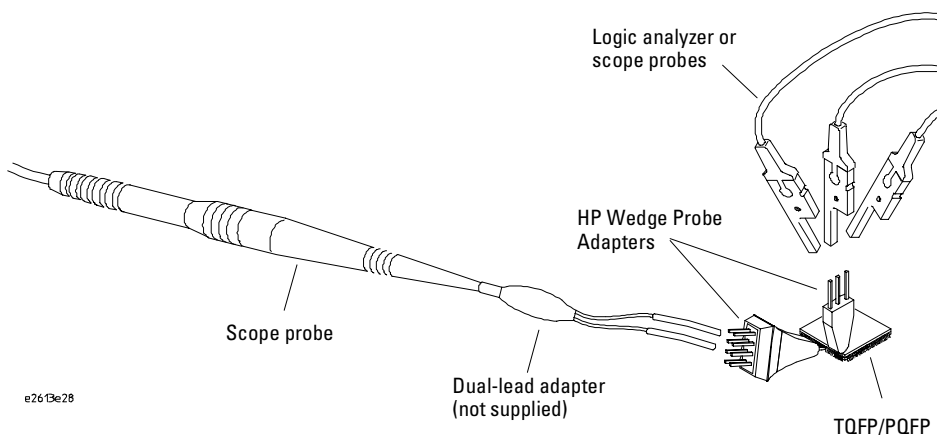

Electrical characteristics

Operating voltage	< 40 V (dc + peak ac)
Operating current	0.5 A maximum
Capacitance between contacts	2 pF typical (all except HP E2643A/44A) 4.33pF typical at 1 MHz (HP E2643A/44A)
Self-inductance	15 nH typical (all except HP E2643A/44A) 37 nH typical at 1 MHz (HP E2643A/44A)
Cross coupling	-31 dB typical at 100 MHz (HP E2643A/44A)
Contact resistance	< 0.1 Ohm

Contents

1 Getting Started

- How the HP Wedge Probe Adapter works 6
- Electrical connections to IC pins 8
- Differences in surface-mounted devices 9
- Supported IC packages and their parameters 10

2 Using the HP Wedge Probe Adapter

- Cleaning your HP Wedge Probe Adapter 12
- Installing your HP Wedge Probe Adapter 13
- Connecting the HP Wedge Probe Adapter to your instrument 15
- Repairing your HP Wedge Probe Adapter 17

How the HP Wedge Probe Adapter works

The HP Wedge Probe Adapter makes contact with legs of the IC under test when the HP Wedge Probe Adapter conductors are inserted into the space between the legs of the IC. The HP Wedge Probe Adapter conductors are connected to pins on the opposite end of the HP Wedge Probe Adapter.

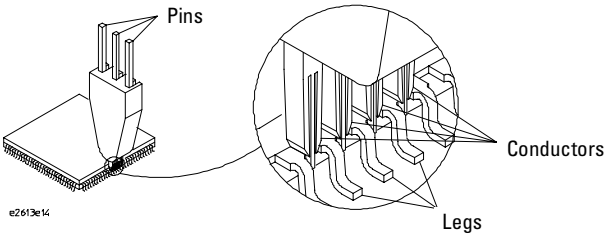

Each HP Wedge Probe Adapter consists of two separate conductors insulated from each other by a center insulator. A shortened insulating adhesive between the center insulator and the outer conductors creates an air gap at the tip of the HP Wedge Probe Adapter.

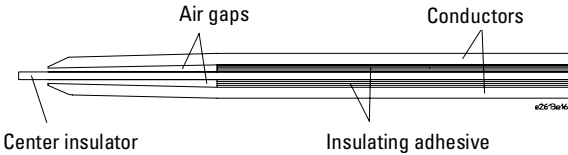

Cross-section view of typical wedge segment

The air gap allows the conductors to conform to the package as the HP Wedge Probe Adapter is inserted between the package legs.

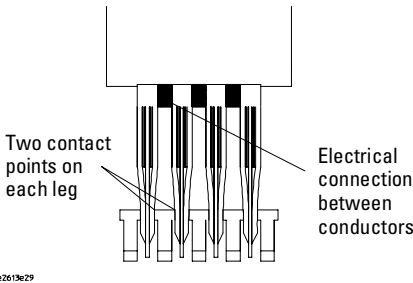

The HP Wedge Probe Adapter has two contact points on each leg of the IC under test. The redundant physical connection between the wedge segments and the legs on the IC package increases reliability of the electrical connection.

CAUTION

Although to the naked eye it's difficult to see the difference between a 0.5 mm and 0.65 mm IC, the HP Wedge Probe Adapter is a precision tool designed for probing at a specific spacing. While it has been tested for 30,000 insertions, damage to the HP Wedge Probe Adapter can easily occur if not used with care.

- 1 Always use the magnifying glass provided to ensure the conductors of the HP Wedge Probe Adapter are accurately aligned with the dam bar gaps before applying pressure to insert.
- 2 Ensure that you use the correct size HP Wedge Probe Adapter for the part you are probing.

If damage occurs to the HP Wedge Probe Adapter, please see "Repairing your HP Wedge Probe Adapter" in chapter 2 of this guide.

Pin-spacing variation on 0.65 mm ICs

There can be a significant variation in the pin spacing of 0.65 mm ICs. While the 0.65 mm HP Wedge Probe Adapter will work with the vast majority of 0.65 mm ICs, we can not guarantee it's performance for all ICs.

Electrical connection to IC pins

If you look closely at the IC-connection end of the 3-signal adapter, you will see there are 4 groups of wedge segments that form 3 gaps. The pins of the IC fit into these gaps of the adapter. Likewise, the 8-signal adapter has 9 groups of wedge segments and 8 gaps, and the 16-signal adapter has 17 groups of wedge segments and 16 gaps that fit into the IC pins.

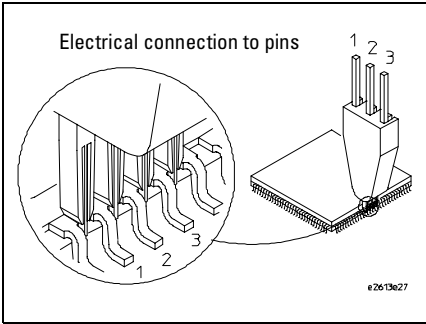

3-signal HP Wedge Probe Adapter

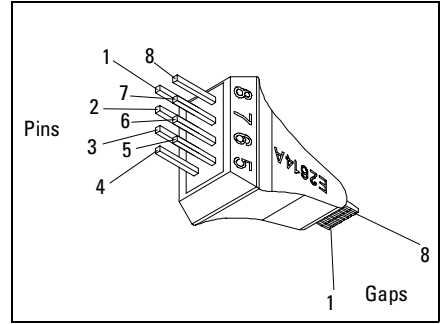

8-signal HP Wedge Probe Adapter

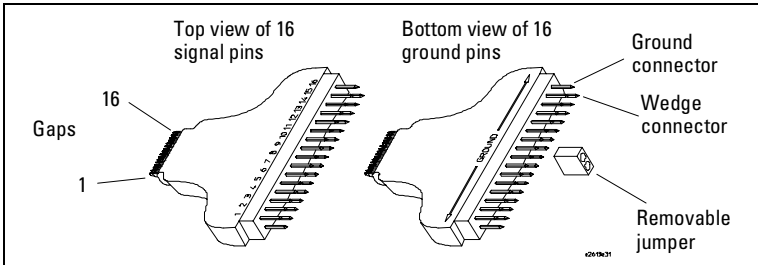

16-signal HP Wedge Probe Adapter

Common ground plane on 16-pin Wedge Probe Adapter

The top side of the 16-pin Wedge Probe Adapter has pins numbered 1 through 16 and provides access to IC signals. The 16 pins (marked GROUND) on the bottom side of the Wedge Probe Adapter are connected together to provide a common ground plane. If any of the signals acquired in the 16-signal segment from the IC are connected to ground, a removable jumper (3 provided) can be used to tie this IC ground signal to the ground plane connected to the bottom 16 pins on the wedge connector. After this connection is made, all 16 bottom pins are connected to ground.

Differences in surface-mounted devices

Dam bars, gaps, and leg spacing

The manufacturing process for making TQFP/PQFPs necessitates the use of a "dam bar." Dam bars prevent the plastic from spewing out between the legs of the part during the molding process.

After the plastic injection process is completed, the residual metal dam bar is removed to allow electrical isolation of each leg, accomplished by a precision blanking die. The remaining gap between the legs of the part is commonly referred to as the "dam bar gap." The dam bar gap is critical for this type of probing because the wedge segments actually make electrical contact with the legs of the TQFP/PQFP package in this area.

When examining a TQFP/PQFP package for probing, check the width of the dam bar gap, and make sure it is free of excess solder. Wicking of solder up the leg and into the dam bar region reduces the dam bar gap width, which can prevent insertion of the HP Wedge Probe Adapter.

Verification of leg spacing (0.5 mm or 0.65 mm) is necessary to ensure that the HP Wedge Probe Adapter will fit properly. Refer to the next section, "Supported ICs and their parameters," for the dimensions of specific ICs.

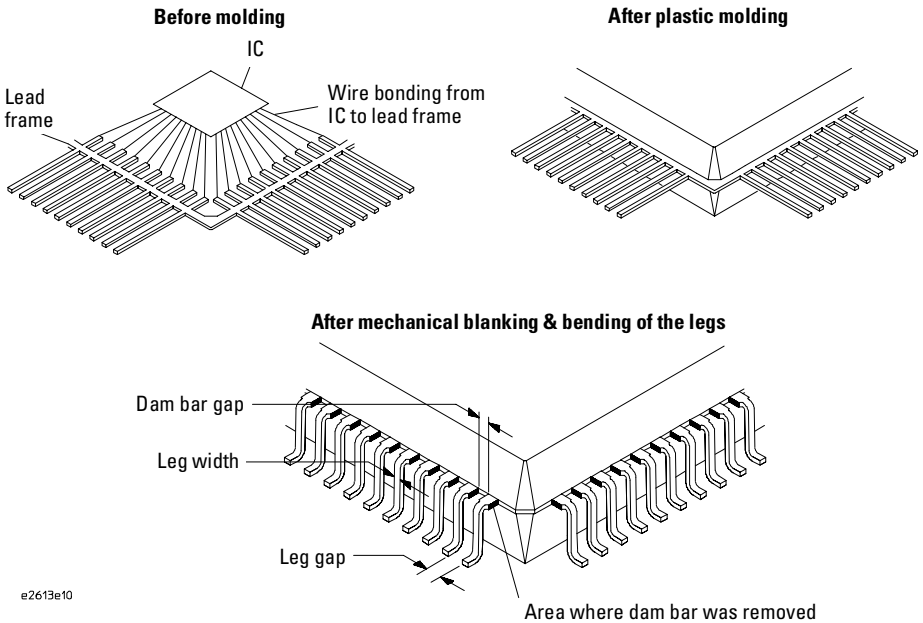

e2613e10

Supported IC packages and their parameters

The following figures show the surface-mounted integrated circuits that are supported.

Typical Plastic Quad Flat Pack

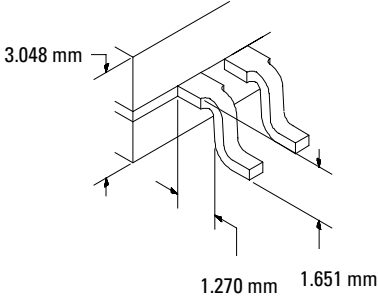

Typical Thin Quad Flat Packs

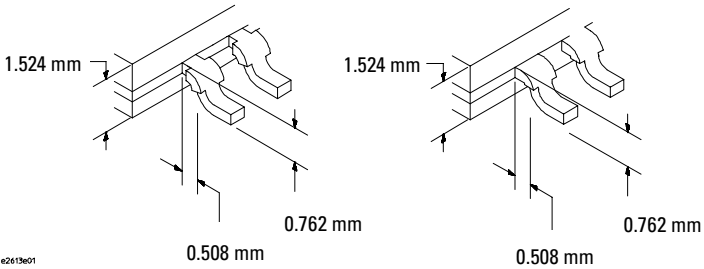

Cleaning your HP Wedge Probe Adapter

Clean the HP Wedge Probe Adapter contacts before each installation. Debris on the contacts will interfere with its function.

- 1** Use a common toothbrush to remove any dust between the wedge segments. The individual wedge segments are very robust and will not be damaged by vigorous brushing.

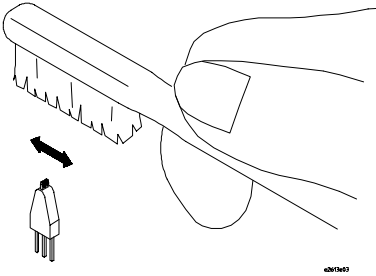

- 2** Use precision dusting cleaner (also known as inert dusting gas or compressed air in a can) to remove debris loosened by the brushing.

Installing your HP Wedge Probe Adapter

CAUTION

Although to the naked eye it's difficult to see the difference between a 0.5 mm and 0.65 mm IC, the HP Wedge Probe Adapter is a precision tool designed for probing at a specific spacing. While it has been tested for 30,000 insertions, damage to the HP Wedge Probe Adapter can easily occur if not used with care.

- 1 Always use the magnifying glass provided to ensure the conductors of the HP Wedge Probe Adapter are accurately aligned with the dam bar gaps before applying pressure to insert.
- 2 Ensure that you use the correct size HP Wedge Probe Adapter for the part you are probing.

If damage occurs to the HP Wedge Probe Adapter, please see "Repairing your HP Wedge Probe Adapter" later in this chapter.

Pin-spacing variation on 0.65 mm ICs

There can be a significant variation in the pin spacing of 0.65 mm ICs. While the 0.65 mm HP Wedge Probe Adapter will work with the vast majority of 0.65 mm ICs, we can not guarantee it's performance for all ICs.

The diagram on the following page shows various techniques for inserting the HP Wedge Probe Adapter, depending on the thickness of the IC and the location of the dam bar gap.

For most PQFP packages, the dam bar gap portion of the IC leg is horizontal to and adjacent to the plastic body of the package, requiring insertion of the HP Wedge Probe Adapter at a 90° angle, as shown in the upper figure.

For thinner packages, such as the TQFP type, the dam bar gap portion of the IC leg is often located on the bend of the leg, requiring insertion of the HP Wedge Probe Adapter at a lesser angle than 90°, as shown in the lower figure.

Chapter 2: Using the HP Wedge Probe Adapter Installing your HP Wedge Probe Adapter

Plastic Quad Flat Pack

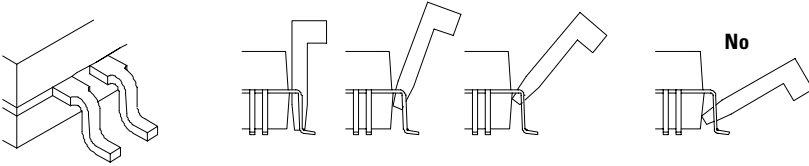

Thin Quad Flat Packs

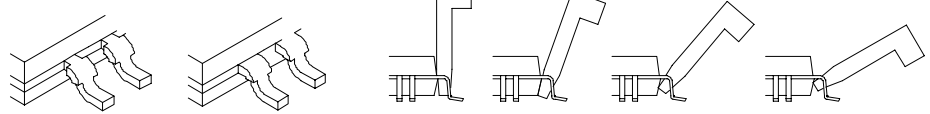

e2613e15

Once the HP Wedge Probe Adapter is properly located between the legs of the IC and in the dam bar gap, apply pressure so the HP Wedge Probe Adapter becomes fully seated. Use caution to insure that the HP Wedge Probe Adapter is inserted at the proper angle to make contact in the dam bar gap area.

After the HP Wedge Probe Adapter is attached, it should have a very solid connection to the IC; you should be able to attach a lead to the HP Wedge Probe Adapter while maintaining a good connection to the IC. If the HP Wedge Probe Adapter becomes loose after you attach it, you likely have one of the following problems:

- the HP Wedge Probe Adapter has not been inserted far enough onto the legs of the IC as shown in the figure above. For this case, you might need to try inserting the HP Wedge Probe Adapter at a different angle, perhaps an angle of less than 30° to the board.
- the HP Wedge Probe Adapter has not been inserted in the dam bar gap portion of the IC leg; as mentioned earlier, the dam bar gap is a thicker part of the IC leg. This thicker part of the IC leg is generally closer to the body of the IC. Try inserting the HP Wedge Probe Adapter on the portion of the IC legs closer to the body of the IC.
- the IC may be a ceramic package which has no dam bar gap. Note that the HP Wedge Probe Adapter is not designed for this type of IC package.

Connecting the HP Wedge Probe Adapter to your instrument

HP oscilloscopes and logic analyzers

The HP Wedge Probe Adapter can be easily attached to HP oscilloscopes or logic analyzers. For HP oscilloscope probes, use a dual lead adapter as shown below.

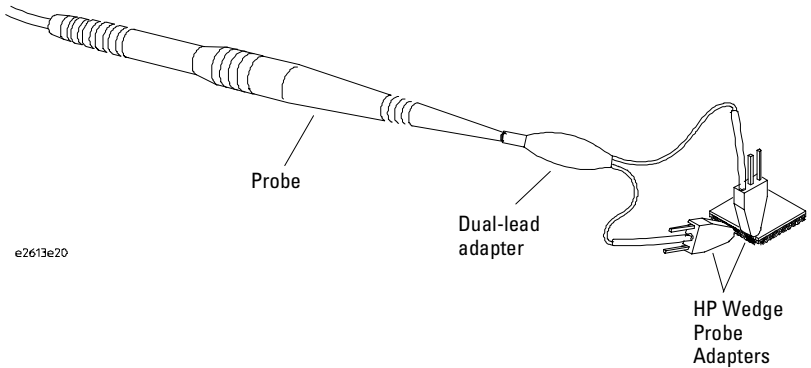

Part numbers for the dual-lead adapter for HP oscilloscope probe families:

HP Probe family	Dual lead Adapter Part Number
HP 1007x	8710-2063
HP 104xxA	5081-7742
HP 104xxB	5063-2147 (included with probe)
HP 116x	5063-2147 (included with probe)

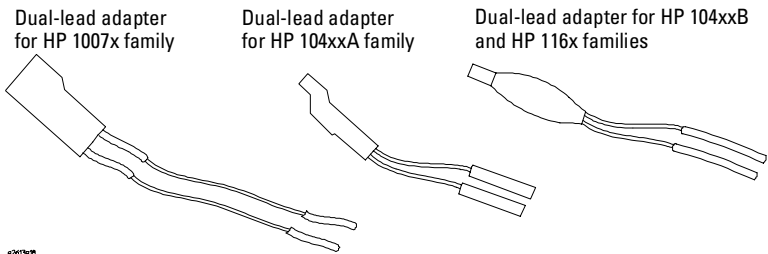

Other instruments

To maintain a solid connection to the HP Wedge Probe Adapter, you will need to use a flexible lead between the probe and the HP Wedge Probe Adapter pins. Without the flexible lead, the weight of the probe on the HP Wedge Probe Adapter will most likely cause the HP Wedge Probe Adapter to disconnect from the IC.

The HP Wedge Probe Adapter pins are 0.635 mm square. If you build your own flexible lead, you will need a socket designed to fit a 0.380- to 0.635-mm square pin at the end of the wire that will be connected to the HP Wedge Probe Adapter. You will need to define the size of the socket at the probe end of the wire.

The probe for your instrument may include flexible leads similar to the dual lead adapters shown earlier in this manual; also, one of the HP dual-lead adapters listed previously may fit your instrument's probe.

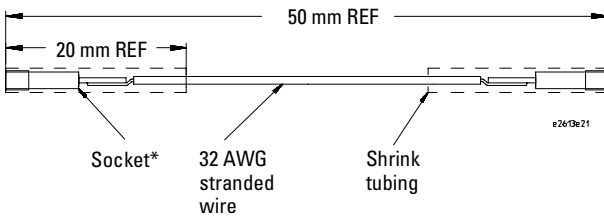

*Mill Max part number 1305-0-15-01-47-14-040 socket

Repairing your HP Wedge Probe Adapter

Typical bent wedge segments

WARNING***Possible injury***

Exercise care when using any sharp tool.

- 1 Use a razor blade between the HP Wedge Probe Adapter conductors to straighten them as much as possible.
- 2 Repeat this on each bent wedge segment conductor.

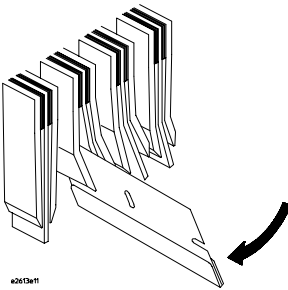

- 3 Hold the HP Wedge Probes Adapter conductors tightly together with tweezers and flex to straighten each individual wedge segment.

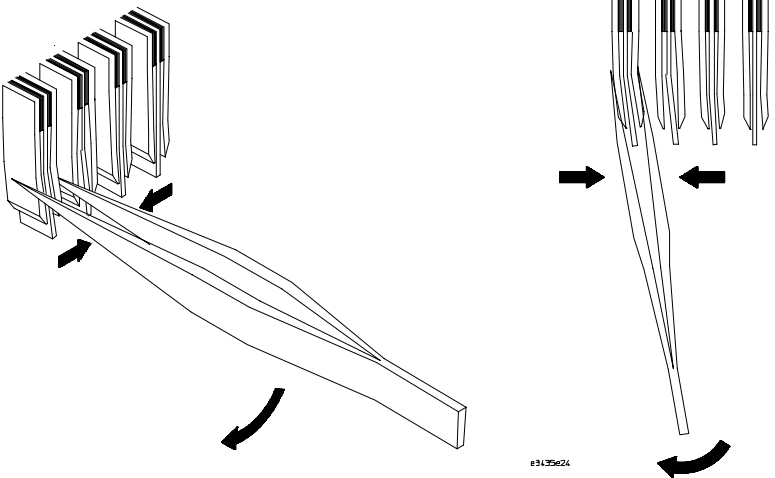

Severely bent wedge segments

- 1 Use a x20 or x40 microscope so you can see the bent wedge segment conductor.
- 2 Use a needle probe to bend the wedge segment conductor enough that you can get tweezers on it.
- 3 Gently straighten out wedge segment conductors using tweezers as shown below.

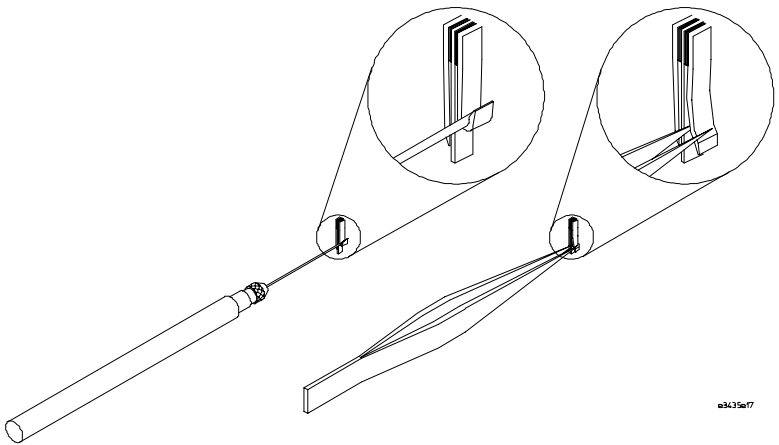

Electrical connection is still often made

Even though the bent section often breaks due to metal fatigue, an electrical connection is often made because there are two electrical contact points on each leg of the TQFP/PQFP package. For more information on how electrical connection is made, see "How the HP Wedge Probe Adapter works" in Chapter 1 of this guide.

Pinched air gap

The air gap is described in chapter 1 of this guide. Wedge segments may fail to make contact if this air gap is closed. The following instructions tell you how to correct this problem.

- 1** Turn the probe so that the wedge segments are facing up.
- 2** Use a x20 or x40 microscope so you can see the pinched wedge segment.

WARNING***Possible injury***

Exercise care when using any sharp tool.

- 3** Insert the edge of a razor blade between the center insulator and the conductor.
- 4** Gently pry the conductor away from the center insulator to open the gap.

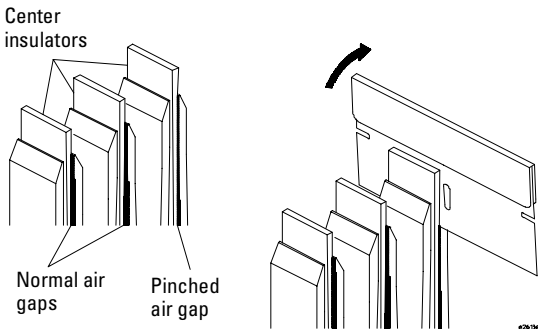

© Copyright Hewlett-Packard Company
1997-1999
All Rights Reserved.

Reproduction, adaptation, or translation without prior written permission is prohibited, except as allowed under the copyright laws.

Restricted Rights Legend.

Use, duplication or disclosure by the U.S. Government is subject to restrictions as set forth in subparagraph (c) (1) (ii) of the Rights in Technical Data and Computer Software clause at DFARS 252.227-7013 for DOD agencies, and subparagraphs (c) (1) and (c) (2) of the Commercial Computer Software Restricted Rights clause at FAR 52.227-19 for other agencies.

Hewlett-Packard Company
3000 Hanover Street
Palo Alto, California
94304 U.S.A.

Document Warranty

The information contained in this document is subject to change without notice.

Hewlett-Packard makes no warranty of any kind with regard to this material, including, but not limited to, the implied warranties of merchantability or fitness for a particular purpose.

Hewlett-Packard shall not be liable for errors contained herein or for damages in connection with the furnishing, performance, or use of this material.

Product Warranty

This Hewlett-Packard product has a warranty against defects in material and workmanship for a period of 90 days from date of shipment. During the warranty period, Hewlett-Packard Company will, at its option, either repair or replace products that prove to be defective.

For warranty service or repair, this product must be returned to a service facility designated by Hewlett-Packard.

For products returned to Hewlett-Packard for warranty service, the Buyer shall prepay shipping charges to Hewlett-Packard and Hewlett-Packard shall pay shipping charges to return the product to the Buyer. However, the Buyer shall pay all shipping charges, duties, and taxes for products returned to Hewlett-Packard from another country.

Hewlett-Packard warrants that its software and firmware designated by Hewlett-Packard for use with an instrument will execute its programming instructions when properly installed on that instrument. Hewlett-Packard does not warrant that the operation of the instrument software, or firmware will be uninterrupted or error free.

Limitation of Warranty

The foregoing warranty shall not apply to defects resulting from improper or inadequate maintenance by the Buyer, Buyer-supplied software or interfacing, unauthorized modification or misuse, operation outside of the environmental specifications for the product, or improper site preparation or maintenance.

No other warranty is expressed or implied. Hewlett-Packard specifically disclaims the implied warranties of merchantability or fitness for a particular purpose.

Exclusive Remedies

The remedies provided herein are the buyer's sole and exclusive remedies. Hewlett-Packard shall not be liable for any direct, indirect, special, incidental, or consequential damages, whether based on contract, tort, or any other legal theory.

Assistance

Product maintenance agreements and other customer assistance agreements are available for Hewlett-Packard products.

For any assistance, contact your nearest Hewlett-Packard Sales Office.

Certification

Hewlett-Packard Company certifies that this product met its published specifications at the time of shipment from the factory. Hewlett-Packard further certifies that its calibration measurements are traceable to the United States National Institute of Standards and Technology, to the extent allowed by the Institute's calibration facility, and to the calibration facilities of other International Standards Organization members.

Safety

This apparatus has been designed and tested in accordance with IEC Publication 1010, Safety Requirements for Measuring Apparatus, and has been supplied in a safe condition. To ensure safe operation and to keep the product safe, the information, cautions, and warnings in this operating manual must be heeded. In addition, note the external markings on the instrument that are described under "Safety Symbols."

Safety Symbols



Instruction manual symbol: the product is marked with this symbol when it is necessary for you to refer to the instruction manual in order to protect against damage to the product.



Hazardous voltage symbol.



Earth terminal symbol: Used to indicate a circuit common connected to grounded chassis.

WARNING

The Warning sign denotes a hazard. It calls attention to a procedure, practice, or the like, which, if not correctly performed or adhered to, could result in personal injury. Do not proceed beyond a Warning sign until the indicated conditions are fully understood and met.

CAUTION

The Caution sign denotes a hazard. It calls attention to an operating procedure, practice, or the like, which, if not correctly performed or adhered to, could result in damage to or destruction of part or all of the product. Do not proceed beyond a Caution symbol until the indicated conditions are fully understood or met.

About this edition

This is the *HP Wedge Probe Adapter User's Guide*.

Publication number
E2613-92006,
June 1999
Printed in USA.

Print history is as follows:
E2613-92006,
June 1999
E2613-92004,
July 1998
E2613-92002,
March 1998
E2613-92000,
November 1997

New editions are complete revisions of the manual. Many product updates do not require manual changes; and, conversely, manual corrections may be done without accompanying product changes. Therefore, do not expect a one-to-one correspondence between product updates and manual updates.



Hewlett-Packard
Printed in the USA

Manual Part Number
E2613-92006

